

PRODUCT INSTALLATION GUIDE

PRODUCT CODE: 4WDSFK
PRODUCT DESCRIPTION: 4WD 2 COUPLER SYSTEM - SELF FIT KIT

KIT CONTENTS:

QTY	PRODUCT	QTY	PRODUCT	QTY	PRODUCT
1	Couplertec Module	3	Heat Shrink Connector	20	Cable Ties
2	Capacitive Coupler	1	Small Ring Terminal 5mm	1	6mm Hex Nut
1	Black Auto Cable x 7m	1	Mini Blade Fuse Holder	2	Alcohol Cleaning Pad
1	Split Loom x 3m	1	Mini Blade Fuse (2Amp)	2	Self - Tapping Screw

TOOLS REQUIRED:

When installing the Couplertec Electronic Rustproofing System, you will need:

- Wire Stripper and Crimper
- Side Cutter
- Shifting Spanner
- 4mm Drill Bit
- 2mm Drill Bit
- Power Drill
- Heat Gun or Cigarette Lighter



PLEASE READ THE FOLLOWING FITTING INSTRUCTIONS CAREFULLY BEFORE PROCEEDING TO INSTALL THE COUPLERTEC ELECTRONIC RUSTPROOFING SYSTEM.

For technical support please contact one of our Couplertec Technical Service Representatives during the following times: Monday – Friday 8.30am – 4.30pm EST. Australia

- **CALLING FROM WITHIN AUSTRALIA:** 1800 068 088
- **INTERNATIONAL CALLERS DIAL:** +61 7 5522 0200

WIRING DIAGRAM (FIGURE: 1)

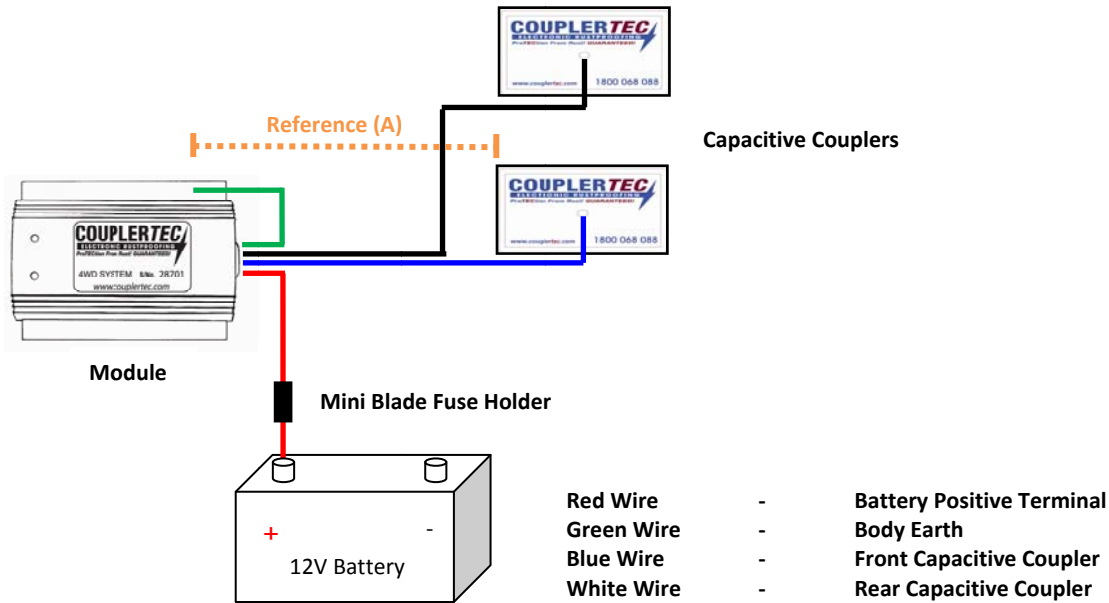

VEHICLE DIAGRAM (FIGURE: 2)

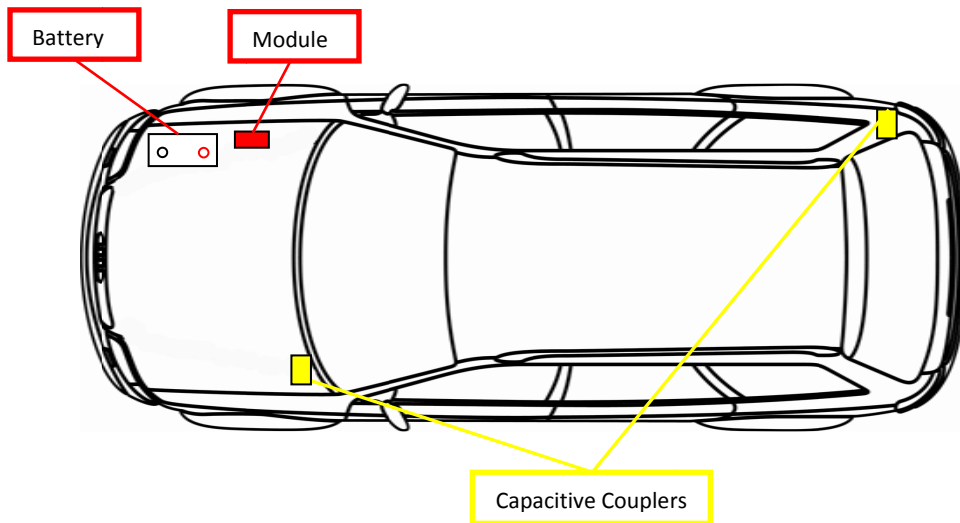

PRE-INSTALLATION INSTRUCTIONS

Selecting a site to locate the Couplertec Module

- The Module should be mounted within the engine bay, if possible, on the same side as the vehicles main/start battery. The Module can be mounted either horizontally or vertically. Try and locate the Module in a site that will not interfere with normal vehicle repair or maintenance, and preferably a site where the two LED indicators are visible. Ensure that there is nothing behind the site that can be damaged by the self-tapping screws which will used to secure the Module to the vehicle.

IMPORTANT INFORMATION: Do not connect the Module to Auxiliary Batteries

Selecting sites to locate the Capacitive Couplers

IMPORTANT INFORMATION: Please ensure that you do not locate Capacitive Couplers within 1m of Radio aerials. Some vehicles produced after 2007 have aerials built into the rear side window, for these vehicles we recommend that you locate the rear Capacitive Coupler on the opposite side of the vehicle to where the aerial is located.

- One Capacitive Coupler should be located at the front of the vehicle on the firewall, inner guard or wheel arch within the engine bay.
- One Capacitive Coupler should be located at the rear of the vehicle, preferably on the inner guard behind the tail light assembly. Access to this area can generally be gained by removing the tail light assembly or internal compartment covers. **For Utility and Cab chassis vehicles, the rear Capacitive Coupler should be fitted to either the left or right hand chassis rail at the rear of the vehicle. If the vehicle is a Dual Cab, then the rear Capacitive Couplers can be fitted to the inner rear wall of the cabin.**

IMPORTANT INFORMATION: The Capacitive Couplers are to be adhered directly to the painted steel surface of the vehicles body. The Capacitive Coupler sites must be:

- Flat (no contoured surfaces)
- Free of indentations, holes or joins in metal work.
- Free of welding slag/spikes
- Well painted with no scratches (if in doubt, apply two coats of quick dry enamel paint to the area).

Fitting the Couplertec Module

- Drill two 4mm holes in the base wings of the Module for fitting. (see fig 3 & 4)

(FIGURES: 3)

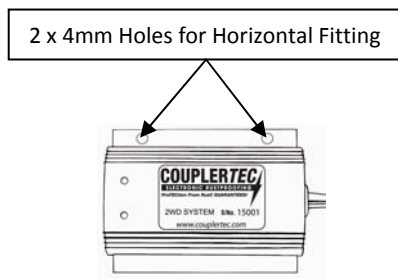

(FIGURES: 4)

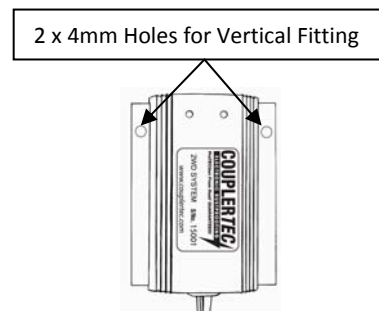

IMPORTANT INFORMATION:

The GREEN wire (earth) must be connected to the body (metal surface) of the vehicle, please ensure that there is a minimum distance of 500mm of metal surface between the nearest Capacitive Coupler and where the GREEN wire is connected. (See Figure: 1 Reference: A).

Where you have a distance of 500mm of metal surface or more between the Module and the Capacitive Coupler, then the GREEN wire can be earthed under the screw head of one of the self tapping screws which is used to fasten the Module to the vehicles body (see figures: 5 & 7).

- Cut the GREEN wire to length, strip the end of the wire and crimp on the Small Ring Terminal ready to be earthed.

(FIGURE: 5)

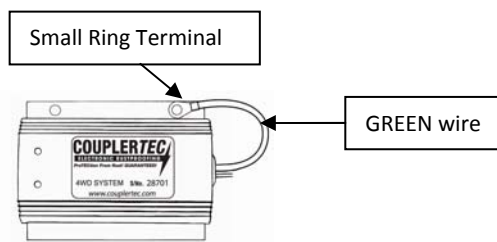

- Whilst holding the Module in the selected position for mounting, mark the positions of the 4mm holes on the body of the vehicle for the placement of the self-tapping screws. (see Figure: 6)
- Using one of the marked positions, drill a 2mm pilot hole into the body of the vehicle and screw 1 x self-tapping screw into the pilot hole to secure the Module to the car.
- Drill the second 2mm pilot hole and place the ring terminal of the GREEN wire under the head of a self-tapping screw, screw to the body of the vehicle.

(FIGURE: 6)

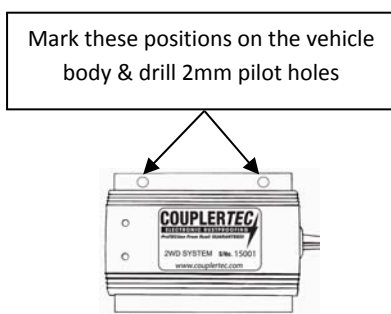

(FIGURE: 7)

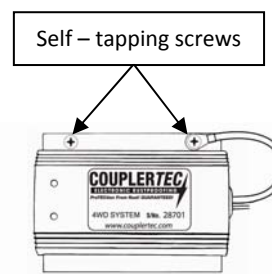

Fitting the Capacitive Couplers

- It is important to thoroughly clean the Capacitive Coupler sites using the alcohol cleaning pads. For extremely dirty sites, use white spirits or similar and a rag to clean the areas, followed by the use of the alcohol cleaning pads.
- Before affixing the Capacitive Couplers, ensure that you strip the end of the BLUE wire which is attached to the Coupler and crimp on a Heat Shrink Connector.
- Peel off the backing paper on the Coupler (don't touch the adhesive surface), firmly press the Capacitive Coupler onto the prepared position making sure that there are no bubbles under the Capacitive Coupler.

IMPORTANT INFORMATION: If you are locating Capacitive Couplers on chassis rails or other areas that may potentially be exposed to water, then you must:

- **Completely seal the entire Capacitive Coupler with a Neutral Cure Silicone Sealant ensuring that the edges of the Capacitive Coupler are sealed to the paintwork.**

Wiring

IMPORTANT INFORMATION: *Run all wiring along the sides of your engine compartment. Be sure to avoid positioning wires too close to hot or moving parts that may melt or pinch the wires. Please ensure that you run all wiring a minimum of 300mm away from Radio aerial wiring, Reversing Camera wiring and Reversing Sensor wiring. When running wires under the vehicle, ensure that there are NO joins under the vehicle. All wiring joins that may potentially be exposed to water should be soldered and sealed with heat shrink. When running wiring through the firewall ensure that you use rubber grommets to protect the wiring. Protect all wiring within the engine bay with split loom. Secure all wiring firmly with cable ties. Existing brake or electrical lines can be used to brace the wiring under the vehicle and within the engine bay.*

Running the power supply wire (RED)

- Run the RED wire from the Module to the positive (+) battery terminal and cut to length. Strip the end of the RED wire (ready to crimp to the Joiner attached to the Mini Blade Fuse Holder).
- Take the Mini Blade Fuse holder and connect the attached ring terminal to the positive (+) battery terminal. Do not undo the nut on the battery terminal unless absolutely necessary, use the 6mm hex nut to tighten up to the existing nut.
- Crimp the RED wire from the Module to the Joiner on the Mini Blade Fuse Holder.

IMPORTANT INFORMATION: DO NOT INSERT THE FUSE AT THIS STAGE.

Wiring the front Capacitive Coupler

- Run the BLUE wire from the Module to the selected Capacitive Coupler site and cut to length.
- Strip the end of the BLUE wire and crimp to the Heat Shrink Connector attached to the Capacitive Coupler.
- Use a heat gun or cigarette lighter to apply heat to the Heat Shrink Connector to seal the connection.

Wiring the rear Capacitive Coupler

- Run the BLACK wire between the engine bay and the rear Coupler site via the chassis rail.
- Strip the end of one WHITE wire coming from the Module and crimp on a Heat Shrink Connector.
- Complete a join between the WHITE and BLACK wires by stripping the end of the BLACK wire and crimping it to the other end of the Heat Shrink Connector.
- Use a heat gun or cigarette lighter to apply heat to the Heat Shrink Connector to seal the connection.
- Strip the end of the BLACK wire which runs to the Capacitive Coupler and crimp to the Heat Shrink Connector attached to the Capacitive Coupler.
- Use a heat gun or cigarette lighter to apply heat to the Heat Shrink Connector to seal the connection.

Insert the fuse into the fuse holder

IMPORTANT INFORMATION: *Once the fuse has been inserted, check for the following;*

- *The Green LED on the Module will glow continuously for 15 - 20 seconds as the Module runs a self diagnostic system test.*
- *A continuous pulsing Green LED confirms a successful installation. This means that the system is functioning correctly.*

If the Red LED flashes then the Module is indicating that there is a fault, see below for fault diagnoses.

- **Red LED flashing continuously:** This means that there is a DEAD SHORT in the wiring. Check all wiring between the Module and the Capacitive Couplers, particularly areas where the wiring comes into contact with metal. If no damage is visible to the wiring, reset the system (Pull the fuse, wait 10 seconds and re-insert the fuse) and observe cycles.
- **Red LED flashes 10 times:** This means OPEN CIRCUIT (a break in the wiring). Check all wiring between the Module and the Capacitive Couplers ensuring that all connections are properly joined. If all connections are secure and there no visible damage to the wiring, reset the system (Pull Fuse, wait 10 seconds and reinsert fuse) and observe cycles.

Red & Green LED'S flashing together 10 times every 60 seconds: This means that the vehicles battery level is low.

- **No LEDS flashing:** Check the fuse & replace if necessary. Check all connections between the positive battery terminal and the Module.